

LTC 9384 Series



Security Systems

EN | Instruction Manual
Outdoor Camera
Housings

BOSCH

Important Safeguards

1. **Read, Follow, and Retain Instructions** - All safety and operating instructions should be read and followed before operating the unit. Retain instructions for future reference.
2. **Heed Warnings** - Adhere to all warnings on the unit and in the operating instructions.
3. **Attachments** - Attachments not recommended by the product manufacturer should not be used, as they may cause hazards.
4. **Installation Cautions** - Do not place this unit on an unstable stand, tripod, bracket, or mount. The unit may fall, causing serious injury to a person and serious damage to the unit. Use only manufacturer-recommended accessories, or those sold with the product. Mount the unit per the manufacturer's instructions. Appliance and cart combination should be moved with care. Quick stops, excessive force, or uneven surfaces may cause the appliance and cart combination to overturn.
5. **Cleaning** - Unplug the unit from the outlet before cleaning. Follow any instructions provided with the unit. Generally, using a damp cloth for cleaning is sufficient. Do not use liquid cleaners or aerosol cleaners.
6. **Servicing** - Do not attempt to service this unit yourself. Opening or removing covers may expose you to dangerous voltage or other hazards. Refer all servicing to qualified service personnel.
7. **Damage Requiring Service** - Unplug the unit from the main AC power source and refer servicing to qualified service personnel under the following conditions:
 - When the power supply cord or plug is damaged.
 - If liquid has been spilled or an object has fallen into the unit.
 - If the unit has been exposed to water and/or inclement weather (rain, snow, etc.).
 - If the unit does not operate normally, when following the operating instructions. Adjust only those controls specified in the operating instructions. Improper adjustment of other controls may result in damage, and require extensive work by a qualified technician to restore the unit to normal operation.
 - If the unit has been dropped or the cabinet damaged.
 - If the unit exhibits a distinct change in performance, this indicates that service is needed.
8. **Replacement Parts** - When replacement parts are required, the service technician should use replacement parts specified by the manufacturer or that have the same characteristics as the original part. Unauthorized substitutions may result in fire, electrical shock or other hazards.
9. **Safety Check** - Upon completion of servicing or repairs to the unit, ask the service technician to perform safety checks to ensure proper operating condition.
10. **Power Sources** - Operate the unit only from the type of power source indicated on the label. If unsure of the type of power supply to use, contact your dealer or local power company.
 - For units intended to operate from battery power, refer to the operating instructions.
 - For units intended to operate **with External Power Supplies**, use only the recommended approved power supplies.
 - For units intended to operate with a limited power source, this power source must comply with EN60950. Substitutions may damage the unit or cause fire or shock.
 - For units intended to operate at 24VAC, normal input voltage is **24VAC**. Voltage applied to the unit's power input should not exceed 30VAC. User-supplied wiring, from the 24VAC supply to unit, must be in compliance with electrical codes (Class 2 power levels). Do not ground the 24VAC supply at the terminals or at the unit's power supply terminals.
11. **Coax Grounding** - If an outside cable system is connected to the unit, ensure that the cable system is grounded. U.S.A. models only - Section 810 of the National Electrical Code, ANSI/NFPA No.70, provides information regarding proper grounding of the mount and supporting structure, grounding of the coax to a discharge unit, size of grounding conductors, location of discharge unit, connection to grounding electrodes, and requirements for the grounding electrode.
12. **Grounding or Polarization** - This unit may be equipped with a polarized alternating current line plug (a plug with one blade wider than the other). This safety feature allows the plug to fit into the power outlet in only one way. If unable to insert the plug fully into the outlet, try reversing the plug. If the plug still fails to fit, contact an electrician to arrange replacement of the obsolete outlet. Do not defeat the safety purpose of the polarized plug. Alternately, this unit may be equipped with a 3-wire grounding plug (a plug with a third pin, for grounding). This safety feature allows the plug to fit into a grounding power outlet only. If unable to insert the plug into the outlet, contact an electrician to arrange replacement of the obsolete outlet. Do not defeat the safety purpose of the grounding plug.
13. **Lightning** - For added protection during a lightning storm, or when this unit is left unattended and unused for long periods of time, unplug the unit from the wall outlet and disconnect the cable system. This will prevent damage to the unit due to lightning and power line surges.

For Indoor Product

1. **Water and Moisture** - Do not use this unit near water - for example, in a wet basement, in an unprotected outdoor installation or in any area classified as a wet location.
2. **Object and Liquid Entry** - Never push objects of any kind into this unit through openings, as they may touch dangerous voltage points or short out parts that could result in a fire or electrical shock. Never spill liquid of any kind on the unit.
3. **Power Cord and Power Cord Protection** - For units intended to operate with 230VAC, 50Hz, the input and output power cord must comply with the latest versions of IEC Publication 227 or IEC Publication 245.
Power supply cords should be routed so they are not likely to be walked on or pinched. Pay particular attention to location of cords and plugs, convenience receptacles, and the point of exit from the appliance.
4. **Overloading** - Do not overload outlets and extension cords; this can result in a risk of fire or electrical shock.

For Outdoor Product

Power Lines - An outdoor system should not be located in the vicinity of overhead power lines, electric lights or power circuits, or where it may contact such power lines or circuits. When installing an outdoor system, extreme care should be taken to keep from touching power lines or circuits, as this contact might be fatal. U.S.A. models only - refer to the National Electrical Code Article 820 regarding installation of CATV systems.

For Rack-mount Product

1. **Ventilation** - This unit should not be placed in a built-in installation or rack, unless proper ventilation is provided, or the manufacturer's instructions have been adhered to. The equipment must not exceed its maximum operating temperature requirements.
2. **Mechanical Loading** - Mounting of the equipment in a rack shall be such that a hazardous condition is not achieved due to uneven mechanical loading.

Safety Precautions



CAUTION
RISK OF ELECTRIC SHOCK. DO NOT OPEN!



CAUTION: TO REDUCE THE RISK OF ELECTRIC SHOCK, DO NOT REMOVE COVER (OR BACK). NO USER SERVICEABLE PARTS INSIDE. REFER SERVICING TO QUALIFIED SERVICE PERSONNEL.



This symbol indicates the presence of uninsulated "dangerous voltage" within the product's enclosure. This may constitute a risk of electric shock.



The user should consult the operating and maintenance (servicing) instructions in the literature accompanying the appliance.









Attention: Installation should be performed by qualified service personnel only in accordance with the National Electrical Code or applicable local codes.









Power Disconnect. Units with or without ON-OFF switches have power supplied to the unit whenever the power cord is inserted into the power source; however, the unit is operational only when the ON-OFF switch is in the ON position. The power cord is the main power disconnect for all units.







Sicherheitshinweise

	VORSICHT ELEKTRISCHE SPANNUNG. NICHT ÖFFNEN!	
<p>VORSICHT: UM EINEN ELEKTRISCHEN SCHLAG ZU VERMEIDEN, IST DIE ABDECKUNG (ODER RÜCKSEITE) NICHT ZU ENTFERNEN. ES BEFINDEN SICH KEINE TEILE IN DIESEM BEREICH, DIE VOM BENUTZER GEWARTET WERDEN KÖNNEN. LASSEN SIE WARTUNGSARBEITEN NUR VON QUALIFIZIERTEM WARTUNGSPERSONAL AUSFÜHREN.</p>		
	Das Symbol macht auf nicht isolierte „gefährliche Spannung“ im Gehäuse aufmerksam. Dies kann zu einem elektrischen Schlag führen.	
	Der Benutzer sollte sich ausführlich über Anweisungen für die Bedienung und Instandhaltung (Wartung) in den begleitenden Unterlagen informieren.	
	Achtung! Die Installation sollte nur von qualifiziertem Kundendienstpersonal gemäß jeweils zutreffender Elektrovorschriften ausgeführt werden.	
	Unterbrechung des Netzanschlusses. Geräte mit oder ohne Netzschalter haben Spannung am Gerät anliegen, sobald der Netzstecker in die Steckdose gesteckt wird. Das Gerät ist jedoch nur betriebsbereit, wenn der Netzschalter (EIN/AUS) auf EIN steht. Wenn das Netzkabel aus der Steckdose gezogen wird, ist die Spannungszuführung zum Gerät vollkommen unterbrochen.	

Precauciones de Seguridad

	ATTENZIONE PERICOLO DI SCOSSA ELETTRICA. NON APRIRE.	
<p>PRECAUCIÓN: PARA DISMINUIR EL RIESGO DE DESCARGA ELÉCTRICA, NO RETIRE LA CUBIERTA (NI LA PARTE POSTERIOR). NO EXISTEN PIEZAS DE RECAMBIO EN EL INTERIOR DEL EQUIPO. EL PERSONAL DE SERVICIO CUALIFICADO SE ENCARGA DE REALIZAR LAS REPARACIONES.</p>		
	Este símbolo indica que existen puntos de tensión peligrosos sin aislamiento dentro de la cubierta de la unidad. Estos puntos pueden constituir un riesgo de descarga eléctrica.	
	El usuario debe consultar las instrucciones de funcionamiento y mantenimiento (reparación) en la documentación que se suministra con el aparato.	
	Atención: la instalación la debe realizar únicamente personal cualificado de conformidad con el National Electric Code o las normas aplicables en su país.	
	Desconexión de la alimentación. Las unidades con o sin interruptores de encendido/apagado reciben alimentación eléctrica siempre que el cable de alimentación esté conectado a la fuente de alimentación. Sin embargo, la unidad sólo funciona cuando el interruptor está en la posición de encendido. El cable de alimentación es la principal fuente de desconexión de todas las unidades.	

Sécurité

	ATTENTION RISQUE D'ÉLECTROCUTION. NE PAS OUVRIR!	
<p>ATTENTION : POUR ÉVITER TOUT RISQUE D'ÉLECTROCUTION, N'ESSAYEZ PAS DE RETIRER LE CAPOT (OU LE PANNEAU ARRIÈRE). CET APPAREIL NE CONTIENT AUCUN COMPOSANT SUSCEPTIBLE D'ÊTRE RÉPARÉ PAR L'UTILISATEUR. CONFIEZ LA RÉPARATION DE L'APPAREIL À DU PERSONNEL QUALIFIÉ.</p>		
	Ce symbole signale que le produit renferme une « tension potentiellement dangereuse » non isolée susceptible de provoquer une électrocution.	
	Ce symbole invite l'utilisateur à consulter les instructions d'utilisation et d'entretien (dépannage) reprises dans la documentation qui accompagne l'appareil.	
	Attention : l'installation doit exclusivement être réalisée par du personnel qualifié, conformément au code national d'électricité américain (NEC) ou au code d'électricité local en vigueur.	
	Coupure de l'alimentation. Qu'ils soient pourvus ou non d'un commutateur ON/OFF, tous les appareils reçoivent de l'énergie une fois le cordon branché sur la source d'alimentation. Toutefois, l'appareil ne fonctionne réellement que lorsque le commutateur est réglé sur ON. Le débranchement du cordon d'alimentation permet de couper l'alimentation des appareils.	

Veiligheidsmaatregelen

	VOORZICHTIG GEVAAR VOOR ELEKTRISCHE SCHOK. NIET OPENEN!	
<p>VOORZICHTIG: OPEN DE BEHUIZING OF DE ACHTERKANT VAN HET APPARAAT NIET. ZO VERMINDERT U HET RISICO OP ELEKTRISCHE SCHOKKEN. IN HET APPARAAT BEVINDEN ZICH GEEN ONDERDELEN DIE U ZELF KUNT REPAREREN. LAAT SERVICE EN ONDERHOUD UITVOEREN DOOR GEKWALIFICEERD PERSONEEL.</p>		
	Dit symbool geeft aan dat er binnen in het apparaat ongeïsoleerde, gevaarlijke spanning aanwezig is die mogelijk elektrische schokken kan veroorzaken.	
	De gebruiker dient de bedienings- en onderhoudsvorschriften te raadplegen in de documentatie die werd meegeleverd met het apparaat.	
	Attentie: het apparaat mag alleen door gekwalificeerd personeel worden geïnstalleerd. De installatie dient in overeenstemming met de nationale elektrische richtlijnen of de van toepassing zijnde lokale richtlijnen te worden uitgevoerd.	
	Spanning uitschakelen. Apparaat met of zonder aan-uitschakelaar staat onder spanning zolang de stekker is aangesloten op de wandcontactdoos. De apparatuur is uitsluitend in werking als de aan-uitschakelaar aan staat. Het netsnoer is de "hoofdschakelaar" voor alle apparatuur.	

Medidas de Segurança

	CUIDADO RISCO DE CHOQUE ELÉCTRICO. NÃO ABRIR!	
<p>CUIDADO: PARA REDUZIR O RISCO DE CHOQUE ELÉCTRICO, NÃO RETIRE A TAMPA (OU A PARTE POSTERIOR). NO INTERIOR, NÃO EXISTEM PEÇAS QUE POSSAM SER REPARADAS PELO UTILIZADOR. REMETA A ASSISTÊNCIA PARA OS TÉCNICOS QUALIFICADOS.</p>		
	<p>Este símbolo indica a presença de "tensão perigosa" não isolada dentro da estrutura do produto, o que pode constituir risco de choque eléctrico.</p>	
	<p>O utilizador deve consultar as instruções de funcionamento e manutenção (assistência) nos documentos que acompanham o aparelho.</p>	
	<p>Atenção: a instalação deve ser executada apenas por técnicos qualificados da assistência, de acordo com o código eléctrico nacional ou os códigos locais aplicáveis.</p>	
	<p>Corte de corrente. As unidades com ou sem interruptores ON-OFF (ligar/desligar) recebem corrente sempre que o fio de alimentação está introduzido na fonte de alimentação; contudo, a unidade apenas está operacional quando o interruptor ON-OFF está na posição ON. O fio de alimentação destina-se a desligar a corrente em todas as unidades.</p>	

Sicurezza

	ATTENZIONE PERICOLO DI SCOSSA ELETTRICA. NON ABRIRE.	
<p>ATTENZIONE: PER RIDURRE IL RISCHIO DI SCOSSE ELETTRICHE NON RIMUOVERE LA COPERTURA (O IL PANNELLO POSTERIORE). L'UNITÀ NON CONTIENE COMPONENTI INTERNI RIPARABILI DALL'UTENTE. PER QUALSIASI INTERVENTO, RIVOLGERSI A PERSONALE TECNICO QUALIFICATO.</p>		
	<p>Questo simbolo indica la presenza di "tensione pericolosa" non isolata all'interno del contenitore del prodotto. Ciò comporta un potenziale rischio di scosse elettriche.</p>	
	<p>Si consiglia di consultare le istruzioni operative e di manutenzione (interventi tecnici) contenute nella documentazione fornita con il dispositivo.</p>	
	<p>Attenzione: l'installazione deve essere effettuata esclusivamente da personale tecnico qualificato in conformità con il National Electrical Code o con le normative locali vigenti.</p>	
	<p>Scollamento dell'alimentazione. Le unità dotate o sprovviste di interruttori ON-OFF vengono alimentate quando si inserisce il cavo nella presa dell'alimentazione. L'unità è tuttavia in funzione solo quando l'interruttore ON-OFF si trova nella posizione ON. Il cavo di alimentazione costituisce il dispositivo di scollamento dell'alimentazione principale per tutte le unità.</p>	

安全预防措施

	CAUTION RISK OF ELECTRIC SHOCK. DO NOT OPEN!	
<p>注意：为避免受到电击，不要拆除机盖（或后盖）。用户不得擅自维修里面的部件。有关维修事项，请咨询合格的维修人员。</p>		
	<p>此符号表示产品机壳内存在未绝缘的“危险电压”。这可能导致电击。</p>	
	<p>用户应参照设备附带的操作和维护（维修）说明。</p>	
	<p>注意：安装须由合格的维修人员遵照美国国家电工标准或相关电气规则进行。</p>	
	<p>断开电源。在电源线插入电源时，配备或未配备 ON-OFF 开关的设备都已通电；但设备只有在 ON-OFF 开关处于 ON 位置时才能工作。对于所有设备，电源线是断开电源的主要方式。</p>	

Table of Contents

Important Safeguards	2
1 UNPACKING	7
2 SERVICE	7
3 CARE AND MAINTENANCE	7
4 DESCRIPTION	7
4.1 Enclosure Rating	7
5 INSTALLATION	7
5.1 Model Designation	7
5.2 Tools Required	8
5.3 Cable Requirements	8
5.4 Cradle Removal	8
5.5 Camera/Lens Installation	9
5.6 Camera/Lense Wiring	9
5.7 Video Coax Connection	12
5.8 Lens Wiring	12
5.9 Final Assembly	12
6 EXPLODED VIEW	14
7 PARTS LIST	14

1 UNPACKING

This electronic equipment should be unpacked and handled carefully.

Check for the following items:

- Verify the unit model number
- Verify that parts listed as follows have been included. See INSTALLATION.

Hardware Kit

Quantity	Part Description
3	Cable Tie
2	BHCS, 1/4-20 x 1/4in.
1	BHCS, 1/4-20 x 5/8in.
1	BHCS, 1/4-20 x 3/4in.
1	BHCS, 1/4-20 x 1/2in.
1	BHCS, 1/4-20 x 3/8in.
1	BHCS, 1/4-20 x 11/4in.
2	0.4mm (0.016in.) Plastic Spacer
1	1.65mm (0.065in.) Plastic Spacer
1	3.9mm (0.154in.) Plastic Spacer
1	7.4mm (0.292in.) Plastic Spacer
1	9.8mm (0.385in.) Plastic Spacer
1	3/8in. NPT Plug
2	Pull Seals

If an item appears to have been damaged in shipment, replace it properly in its carton and notify the shipper. If any items are missing, notify your Bosch Security Systems Inc. Sales Representative or Customer Service.

The shipping carton is the safest container in which the unit may be transported. Save it for possible future use.

2 SERVICE

If the unit ever needs repair service, the customer should contact the nearest Bosch Security Systems, Inc. Service Center for return authorization and shipping instructions.

Service Centers

USA

Phone: 800-366-2283 or 717-735-6638
 fax: 800-366-1329 or 717-735-6639

CCTV Spare Parts

Phone: 800-894-5215 or 408-956-3853 or 3854
 fax: 408-957-3198
 e-mail: BoschCCTVparts@ca.slr.com

Canada

Phone: 514-738-2434

Europe, Middle East & Asia Pacific Region

Phone: 32-1-440-0711

For additional information, see
www.boschsecuritysystems.com.

3 CARE AND MAINTENANCE

Clean the viewing window as needed with a mild, nonabrasive detergent in water and a soft cloth.

4 DESCRIPTION

The LTC 9384 Series of environmental housings are attractive aluminum enclosures designed for outdoor CCD camera installations.

4.1 Enclosure Rating

4.1.1 NEMA-3R and IP54

The LTC 9384 Series Housings include a *breather* hole in the front face cap. The *breather* hole prevents the accumulation of moisture inside the housing when installed in areas of high humidity. With the *breather* hole open, the LTC 9384 Series Housings meet the enclosure rating requirements of NEMA-3R and IP54.

4.1.2 NEMA-4 and IP65

For installations requiring an enclosure rating of NEMA-6P or IP68, the *breather* hole must be plugged using the *pull seal* (Part No. 315 2569 001) provided in the hardware kit. Refer to Final Assembly under INSTALLATION for proper installation.

5 INSTALLATION



Qualified service persons should handle this installation. Installation must conform to all local codes.

5.1 Model Designation

Power Transformer¹

Model No.	Rated Input	Voltage Range	Voltage Output	Nominal Power ¹
LTC 9384/60	115VAC,	108 to 132	24VAC,	30W
	50/60Hz		50/60Hz	
LTC 9384/20	24VAC,	21.6 to 26.4	24VAC,	30W
	50/60Hz		50/60Hz	
LTC 9384/50	230VAC,	207 to 253	24VAC,	30W
	50/60Hz		50/60Hz	
LTC 9384/20NT	24VAC,	21.6 to 26.4	—	30W
	50/60Hz			

¹The power transformers included with these housings are used to provide heater power and can be used to provide isolated camera power.

²Heater requires 10 watts.

Do Not Exceed 30VAC Input on 24VAC models.

Operation above 30VAC violates low voltage operation (Class 2 Specifications). Normal operation is 24VAC.

Maximum Camera/Lens Size:

LTC 9384/xx:

Accepts cameras up to 64W x 54H mm (2.5 x 2.1in.), lenses up to 67W x 75H mm (2.6 x 2.9in.), and camera/lens combinations up to 292mm (11.5in.).

LTC 9384/20NT:

Accepts cameras up to 64W x 54H mm (2.5 x 2.1in.), lenses up to 67W x 75H mm (2.6 x 2.9in.), and camera/lens combinations up to 355mm (14.0in.).

5.2 Tools Required

- Flat blade screwdriver
- Phillips head screwdriver
- 5/32in. (or 4mm) hex wrench
- 5/16in. (or 8mm) hex wrench
- Adjustable wrench
- Wire cutter/stripper/crimper tool

5.3 Cable Requirements

Video Transmission (Coaxial)	
Cable Type	RG-59/U (Runs < 1000ft) RG-11/U (Runs < 2000ft)
Cable Size	Outside diameter between 4.6mm (0.181in.) and 7.9mm (0.312in.)
Cable Shape	Round
Shield	≥ 93% Braided Copper Shield
Center Conductor	Stranded Copper Center
DC Resistance	≥ 15Ω/1000ft (RG-59/U) ≥ 6Ω/1000ft (RG-11/U)
Cable Impedence	75Ω
Agency Rating	UL
Environmental	Outdoor rated
Temperature Rating	≥ 80 °C (176 °F)
Sources	Belden 9259 Belden 9238

Input Power Cord - North American	
Cable Type	SJTOW-A Rated
Cable Size	Outside diameter between 4.3mm (0.170in.) and 11.9mm (0.470in.)
Cable Shape	Round
Conductors	3 conductor version and 2 conductor version
Agency Rating	UL/C.S.A., UL VW-1
Environmental	Outdoor rated
Temperature Rating	105 °C (221 °F)
Voltage Rating	300 V
Sources	Belden 19506 Belden 19509 Northwire 573939

Input Power Cord - European	
Cable Type	H05RN-F3G0.75 and H05RN-F3G1.00
Cable Size	Outside diameter between 4.3mm (0.170in.) and 11.9mm (0.470in.)
Cable Shape	Round
Conductors	3 conductor version and 2 conductor version
Agency Rating	VDE
Environmental	Outdoor rated
Sources	Olflex 1600252 Olflex 1600253

Lens Control Cable	
Cable Type	Jacketed Multiconductor Cable
Cable Size	Outside Diameter between 4.3mm (0.170in.) and 11.9mm (0.470in.)
Cable Shape	Round
Shield	Overall shielding
Conductors	Stranded 20 to 16 AWG wire
No. of Conductors	4 and 8
Conductor Insulation	Color coded
Sources	Belden 9552 Belden 9554

5.4 Cradle Removal

1. Remove the cradle from the housing by lowering the retaining screw completely on the bottom rear of the housing.
2. Remove the cradle assembly by pushing gently on the metal part of front cap and simultaneously grasping the rear handle and pulling the cradle assembly out of the housing. Be sure to keep the edges of the endcaps clean and free of scratches (see FIGURE 1).

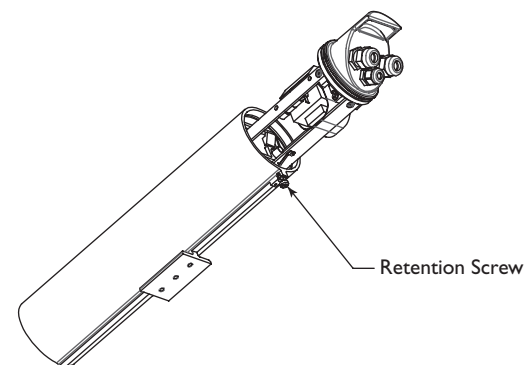

FIGURE 1 Removing the Cradle Assembly

5.5 Camera/Lens Installation

With the cradle removed from the housing, place the camera/lens combination into the cradle assembly.

1. **Fixed Lens Cameras:** Position the camera/lens 1mm (0.04in.) away from the faceplate. The camera/lens is secured to the cradle with a 1/4-20 button head cap screw (BHCS) and the appropriate plastic spacer (see FIGURE 2).

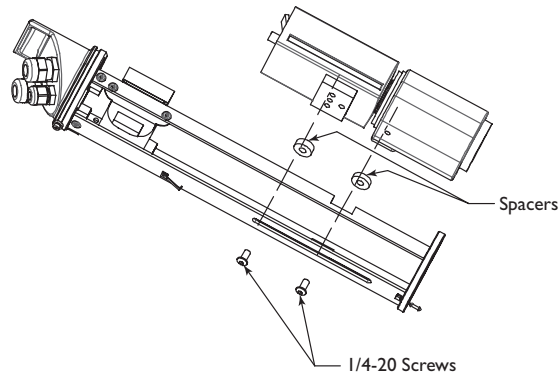

FIGURE 2 Mounting the Camera and Lens

2. **Zoom Lens Cameras:** Allow 3/16in. (5mm) clearance from the front face of the lens to the front faceplate of the cradle during the camera/lens assembly. This clearance provides the necessary space for the lens to extend outward when zooming. Secure both the camera and the lens to the cradle with the 1/4-20 BHCS and appropriate plastic spacer.

5.6 Camera/Lens Wiring

WARNING: Use only the cables specified under INSTALLATION, Cable Requirements for wiring of all cameras and lenses.

5.6.1 General

1. The dual male threaded portion of the three (3) liquid tight fittings, two (2) NPT 1/2in., and one (1) NPT 3/8in., located in the rear of the cradle, are preinstalled to a specified torque to prevent entrance of water. Do not remove or loosen these parts. The two large fittings are supplied with seal glands for cables with diameters from 4.3mm to 11.9mm (0.17in. to 0.47in.). The small fitting will accept cables with diameters from 4.6mm to 7.9mm (0.181in. to 0.312in.) see FIGURE 3.



Securely tighten all fittings to ensure a liquid-tight seal. Failure to do so could allow water to enter the housing and damage the camera and lens.

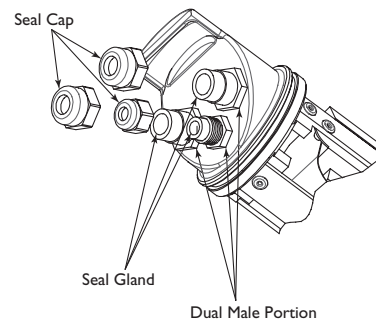

FIGURE 3 Liquid Tight Fitting Assembly

If a sealant is to be used, be sure it is a neutral cure type. Sealants that release acetic acid may harm camera electronics.

If it is necessary to use a PG type conduit, an NPT to PG Conversion Kit (LTC 9381/00) can be purchased separately.



Use of drip loops is recommended on the wiring outside of the rear endcap.

5.6.2 Plug Insertion

If no lens control or feed-through wiring will be used, remove the preinstalled 3/8in. liquid-tight fitting from the small bottom center hole and install the 3/8in. NPT plug provided. Use a 8mm (5/16in.) hex wrench to tighten. Failure to do so will allow water to enter and cause damage to all electronic parts (see FIGURE 4).

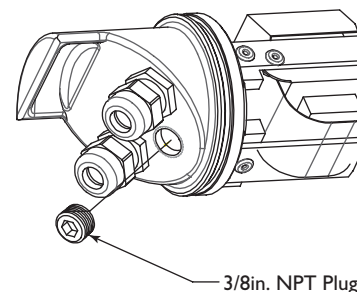

FIGURE 4 3/8in. NPT Plug Insertion

5.6.3 Power Connections

The LTC 9384 Series Housings (except the nontransformer LTC 9384/20NT version) allow the use of 24VAC cameras, regardless of the supply voltage to the housing. This is achieved via transformer in the housing. The transformer's primary supply power varies, depending on the model of housing, (see Section 5.1 Model Designation). In the 115 volt and 230 volt models, the transformer also supplies 24VAC power to the integral window heater/defogger.

1. Use the liquid-tight fitting on the left-hand side of the housing to route the power wire into the housing.

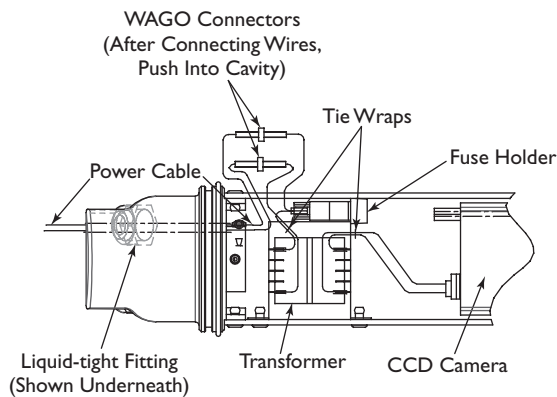

FIGURE 5 Power Connections

2. A screw/terminal lug is provided for securing a safety ground. Attach the terminal lug to the cradle using the M4 x 10 screw provided.

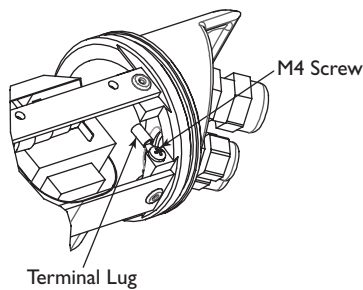

FIGURE 6 Securing the Ground Wire

3. Pull any excess wire out of the cradle assembly and tighten the fitting to 8.5 N.m to 9.0 N.m (75in. lb to 80in. lb). This torque rating is approximately 1 to 1 1/2 turns past the point where the fitting starts to grip the wire. Failure

to do so will allow water to enter and damage all electronic parts. Use a tie wrap (included) to provide strain relief on the power cord at the exit point (inside the unit).



Securely tighten all fittings to ensure a liquid-tight seal. Failure to do so could allow water to enter the housing and damage the camera and lens.

Select the appropriate wiring instructions from this section, depending on which Housing is being used:

5.6.4 LTC 9384/60 Housings

The LTC 9384/60 Housings can easily be used with either 115 volt or 24 volt cameras.

The internal transformer provides 24VAC for both the heater/defogger and 24 volt camera power (see FIGURE 5).

For 115 Volt Cameras:

1. Installing a 115 volt camera into the LTC 9384/60 housing requires the camera's line cord to be cut and connected with the transformer primary leads and the power supply line (see FIGURE 7).
2. The secondary flying leads (white/black striped) will not be used in this application, and should be taped to prevent shorting. See wiring diagram FIGURE 7 for clarification and FIGURE 5 for power connection drawings.

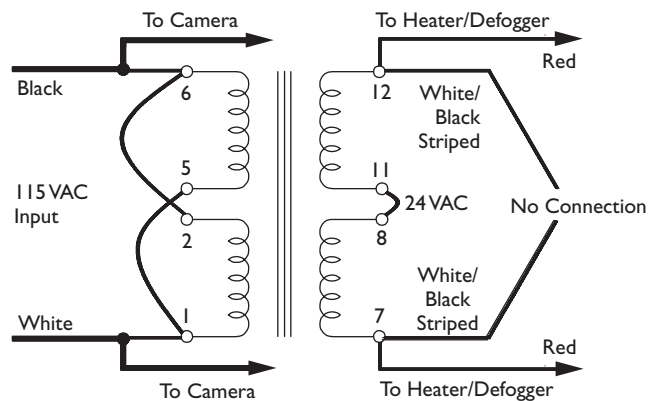

FIGURE 7 LTC 9384/60 Transformer Wired for 115 Volt Camera

For 24 Volt Cameras:

1. Installing a 24 volt camera into the LTC 9384/60 Housing uses the internal transformer for camera power (see FIGURE 7).
2. Connect the supply (115VAC) to the primary flying leads of the transformer (white wire/pin 1, black wire/pin 6). Use the wire nuts provided for this connection.
3. Connect the secondary flying leads (white/black striped wires/pins 7 and 12) to the camera's 24 volt input. See wiring diagram FIGURE 8 for clarification and FIGURE 5 for power connection drawings.

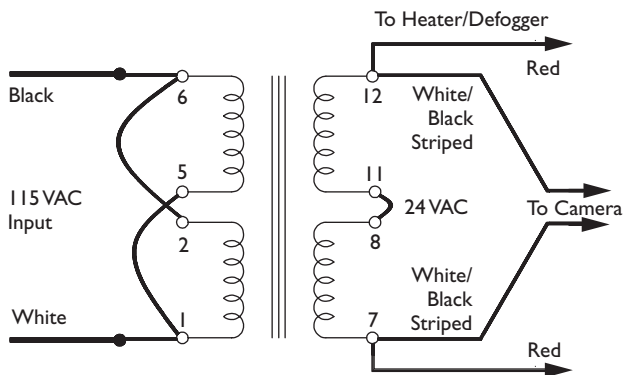

FIGURE 8 LTC 9384/60 Transformer Wired for 24 Volt Camera

5.6.5 LTC 9384/20 Housings

These housings are to be connected to 24VAC only, and are designed for use where the site power is 24 volts.

The LTC 9384/20 housings are designed to be used with 24 volt cameras only.

1. Connect the supply (24VAC) to the primary flying leads of the transformer. Use the wire nuts provided for this connection (see FIGURE 9).
2. Connect the secondary flying leads to the camera's 24 volt input. See wiring diagram FIGURE 9 for clarification and FIGURE 5 for power connection drawings.

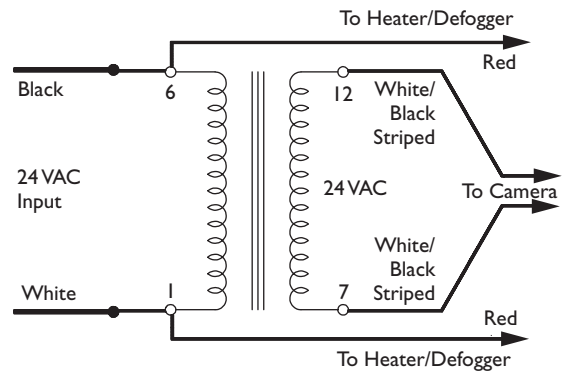

FIGURE 9 LTC 9384/20 Transformer Wired for 24 Volt Camera

5.6.6 LTC 9384/50 Housings

These housings require connection to 230VAC, and are designed for use where the site power is 230 volts.

The LTC 9384/50 Housings can easily be used with either 230 volt or 24 volt cameras.

The internal transformer provides 24VAC for both the heater and 24 volt camera power.



Do not remove the transformer insulator. No user serviceable parts are present.

For 230 Volt Cameras:

1. Installing a 230 volt camera into the LTC 9384/50 housing requires the camera's line cord to be cut and connected with the transformer's primary wiring and the power supply line (see FIGURE 10).
2. The secondary flying leads (white/black striped) will not be used in this application, and should be taped to prevent shorting. See wiring diagram FIGURE 10 for clarification and FIGURE 5 for power connection drawings.

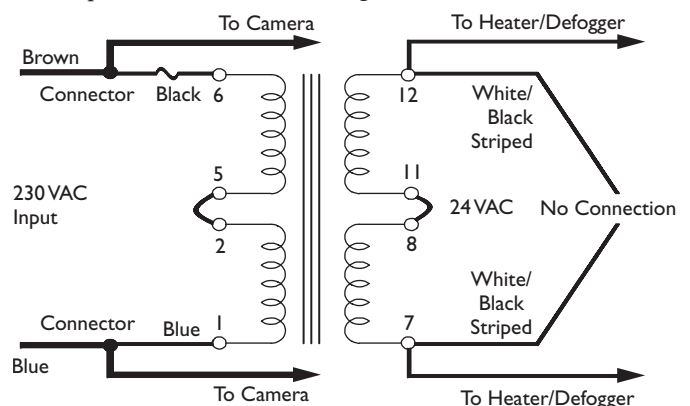

FIGURE 10 LTC 9384/50 Transformer Wired for 230 Volt Camera

For 24 Volt Cameras:

1. Installing a 24 volt camera into the LTC 9384/50 housing uses the internal transformer for camera power (see FIGURE 11).
2. Connect the supply (230VAC) to the terminal block. Use only the terminal block provided for this connection.
3. Connect the secondary flying leads to the camera's 24 volt input. Refer to the wiring diagram for clarification.

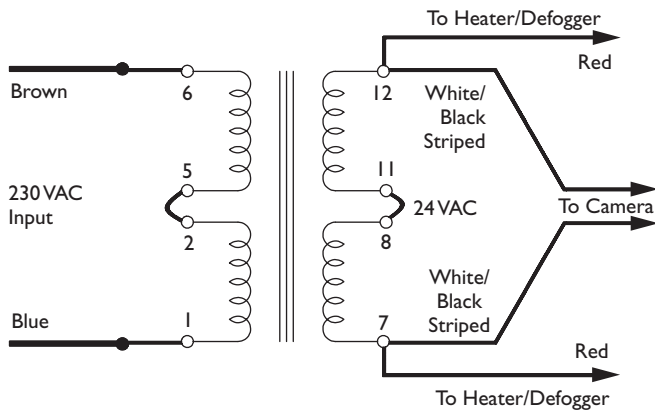



FIGURE 11 LTC 9384/50 Transformer Wired for 24 Volt Camera

5.7 Video Coax Connection

 **WARNING:** Use only the cables specified under INSTALLATION, Cable Requirements for video coax wiring connection.

If no lens control or feed-through wires will be used:

1. Install the seal cap portion of the large liquid-tight fitting on the video coax cable, and pull the cable through the right-hand fitting on the rear of the cradle. If lens control is used, pull the cable through the small bottom fitting.
2. Attach the BNC connector to the coax and connect it to the camera. Pull any excess wire out of the cradle assembly and tighten approximately 1 to 1 1/2 turns past the point where the fitting starts to grip the wire. Failure to do so will result in water damage to all electronic parts. Use a tie wrap (included) to provide strain relief on the video cable at the exit point (inside the unit).

3. Install the 3/8in. NPT plug provided in the unused, small top center NPT hole.



Securely tighten all fittings to ensure a liquid-tight seal. Failure to do so could allow water to enter the housing and damage the camera and lens.

5.8 Lens Wiring



WARNING: Use only the cables specified under INSTALLATION, Cable Requirements for video coax wiring connection.

1. If installing a zoom lens, insert the lens control cable with the installed seal cap in through the right fitting at the rear of the cradle. Attach the lens wiring to the lens mating connector and connect it to the lens. If the mating connector is not available, connect directly to the lens cable.

NOTE: See the specification on lens cord for the correct plug connection.



Securely tighten all fittings to ensure a liquid-tight seal. Failure to do so could allow water to enter the housing and damage the camera and lens.

2. If using a pan/tilt with a feed-through cable, insert the camera/lens function cable in through the right-hand fitting at the rear of the cradle. Wire the functions as described above or as needed.



Use of drip loops is not recommended on the wiring outside of the rear endcap.

5.9 Final Assembly

5.9.1 Pull Seal Installation



If the breather hole is open, do NOT mount the housing in a position where the front endcap is pointed upward.

To maintain enclosure protection ratings of NEMA-6P and IP68, the pull seal (provided in the hardware kit) must be installed in the front endcap. Install the pull seal in a cool, dry environment to prevent trapping moisture inside the housing (see FIGURE 12).

NOTE: Pull seal installation allows the housing's front endcap to be pointed upward.

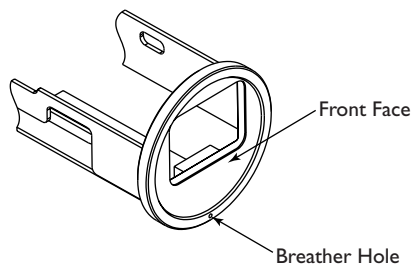

FIGURE 12 Breather Hole

Proper installation of the pull seal is as follows:

1. Remove the cradle assembly from the housing.
2. Obtain a rubber pull seal (Part Number 315 2569 001) from the hardware kit (see FIGURE 13). An extra pull seal is also provided.

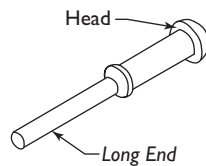

FIGURE 13 Pull Seal

3. Insert the long end of the pull seal into the breather hole starting from the front of the endcap (see FIGURE 14).

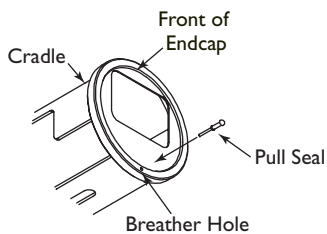

FIGURE 14 Inserting the Pull Seal

4. Grip the pull seal's long end from the back of the front endcap. Steadily pull the long end until the head of the pull seal is flat against the front of the endcap (see FIGURE 15).

NOTE: The pull seal's long end will stretch when pulled through the breather hole.

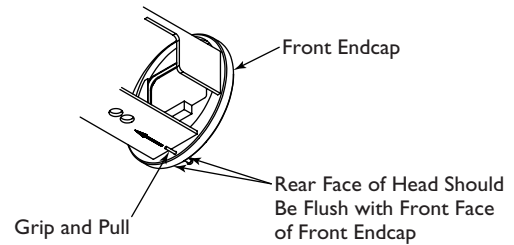

FIGURE 15 Installing the Pull Seal

5.9.2 Cradle Assembly

1. Position the housing vertically and replace the cradle assembly by applying pressure onto the rear cap until the end of the cradle is approximately flush with the back of the housing (see FIGURE 16).

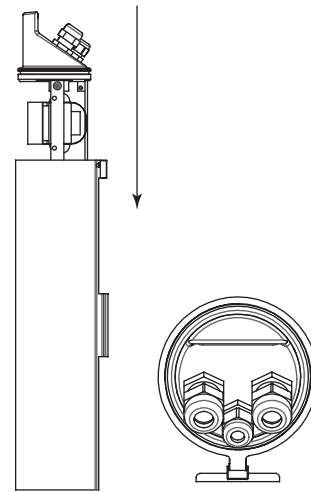

FIGURE 16 Inserting the Cradle Assembly



CAUTION: If a pull seal is installed in the breather hole, be careful not to pinch the head of the pull seal. Damage to the pull seal may allow water to enter the housing, causing damage to the camera and lens.

2. Tighten the retention screw, making sure it is seated into the rear cap groove. If the housing needs to be tamper-resistant, the LTC 9380/02 (purchased separately) should be installed at this time.
3. Attach the housing to the appropriate mount or pan/tilt per the instructions provided. According to the orientation of the housing, the cradle assembly may need to be rotated. To rotate the cradle assembly (while mounted), grasp the rear handle and rotate it to the desired position. View the monitor while rotating.

6 EXPLODED VIEW

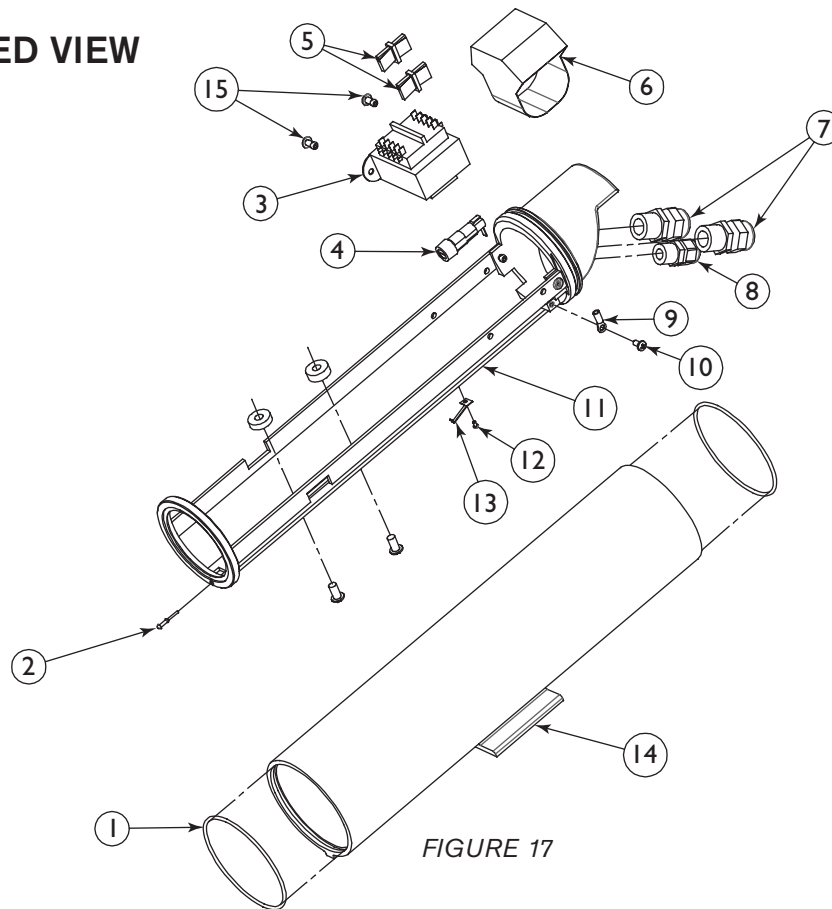

FIGURE 17

7 PARTS LIST

Ref No.	Part Number	Qty.	Part Description
---------	-------------	------	------------------

Heyco Fitting Kit – 315 3802 001

7	-	2	$\frac{3}{4}$ NPT
8	-	1	$\frac{3}{8}$ NPT

Cradle Assembly Kit – 315 3803 001

11	-	1	Cradle/Heater Assembly
9	-	1	Ring Tongue Terminal
13	-	1	Ground Slide
10	-	1	M4 Phillips Head Screw
12	-	1	XXX Phillips Head Screw
2	-	1	Pull Seal

115 VAC Prewired Transformer Kit – 315 3804 001

3	315 3808 001	1	115VAC Prewired Transformer
15	-	2	Rivet, $\frac{5}{16}$ in.
6	-	1	Transformer Insulator

24 VAC Prewired Transformer Kit – 315 3805 001

3	315 3809 001	1	24VAC Prewired Transformer
15	-	2	Rivet, $\frac{5}{16}$ in.
6	-	1	Transformer Insulator

230 VAC Prewired Transformer Kit – 315 3806 001

3	315 3810 001	1	230VAC Prewired Transformer
15	-	2	Rivet, $\frac{5}{16}$ in.
6	-	1	Transformer Insulator

Housing Kit – 315 3807 001

11	-	1	Housing
1	-	2	Silicone O-ring

HARDWARE KIT

Hardware Kit - 315 1514 005

Quantity	Part Description
3	Cable Tie
2	BHCS, $\frac{1}{4}$ -20 x $\frac{1}{4}$ in.
1	BHCS, $\frac{1}{4}$ -20 x $\frac{5}{16}$ in.
1	BHCS, $\frac{1}{4}$ -20 x $\frac{3}{8}$ in.
1	BHCS, $\frac{1}{4}$ -20 x $\frac{1}{2}$ in.
1	BHCS, $\frac{1}{4}$ -20 x $\frac{3}{4}$ in.
1	BHCS, $\frac{1}{4}$ -20 x $1\frac{1}{4}$ in.
2	0.4mm (0.016in.) Plastic Spacer
1	1.65mm (0.065in.) Plastic Spacer
1	3.9mm (0.154in.) Plastic Spacer
1	7.4mm (0.292in.) Plastic Spacer
1	9.8mm (0.385in.) Plastic Spacer
1	$\frac{3}{8}$ in. NPT Plug
2	Pull Seals

Bosch Security Systems, Inc.
850 Greenfield Road
Lancaster, PA 17601 USA
Tel: 800-326-3270
Fax: 1-717-735-6560
www.boschsecuritysystems.com

Bosch Security Systems B.V.
P.O. Box 80002
5600 JB Eindhoven
The Netherlands
Tele +31 40 27 80000

Bosch Security Systems Pte Ltd.
38C Jalan Pemimpin
Singapore 577180
Republic of Singapore
Tel: 65 (6) 319 3486

© 2004 Bosch Security Systems GmbH
3935 890 40912 04-36 | September 1, 2004 | Data subject to change without notice.

BOSCH